

INVISIBLE HINGE

天地铰链系列



精致小巧的体型，集合缓冲与三维调节功能，结合技术与美学的完美典范！

Small body, widely used, With integrated damper and 3D adjustment, combined by technology and aesthetic.



- 安装在柜体底板和顶板
- 适用于18毫米木门及铝框门
- 金属杯深: 15毫米
- 开启角度: 105°
- 门板钻孔距离(K)值: 木门从3~6毫米
- 表面处理: 钛金黑、镀镍
- Apply in hat and in base of the cabinet
- For doors of minimum thickness wood 18 mm and with aluminum frame doors
- Depth canister: 15 mm
- Opening: 105°
- Possibility of drilling the wing: K 3 to 6 mm for wooden doors
- Finishing: black or nichel

开门所需间隙 Space required for the door opening

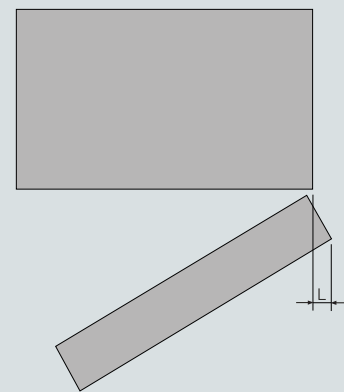

D \ L	L18	L20	L22	L24	L26	L28	L30	L32
D3	0.0	0.2	0.5	0.9	1.4	2.1	3.1	4.7
D4	0.0	0.2	0.5	0.9	1.4	2.0	2.9	4.2
D5	0.0	0.2	0.5	0.8	1.3	2.0	2.8	3.9
D6	0.0	0.2	0.5	0.8	1.3	1.9	2.7	3.7

注:
L18~32: 门板厚度 Board thickness
D3~6: 门板外线与铰杯钻孔距离 Distance between door edge and drilling holes on hinge cup

关门角度 Door return

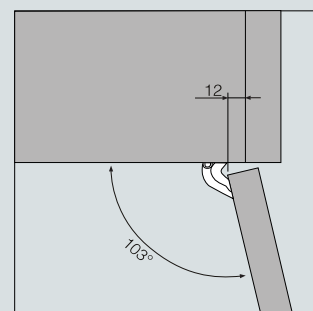

调节范围 Adjustments

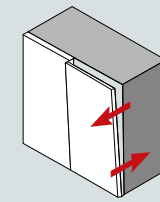

门缝调节: +2 / -0.5mm
Frontal adjustment: +2 / -0.5mm

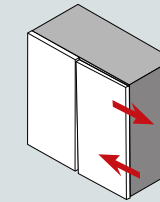

盖板调节: +1.5 / -1.5mm
Lateral adjustment: +1.5 / -1.5mm

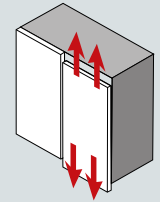

上下调节: +1.0 / -1.0mm
Vertical adjustment: +1.0 / -1.0mm

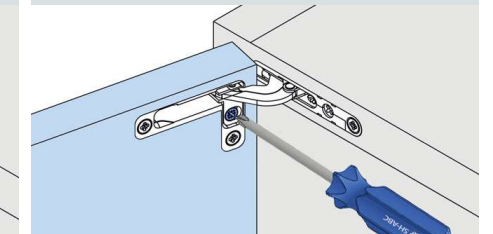
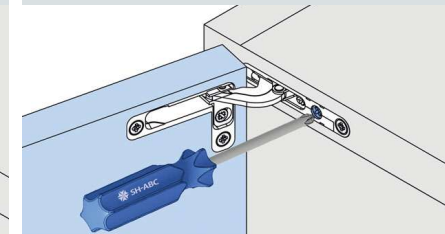
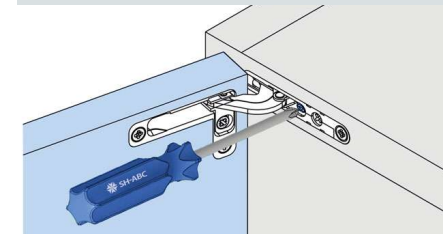

门板开孔尺寸 Working on wood cabinet

底板 Base/Hat

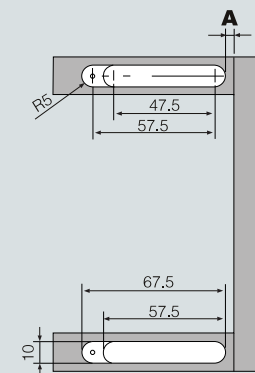

门板 Door

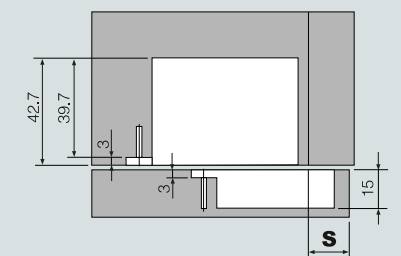
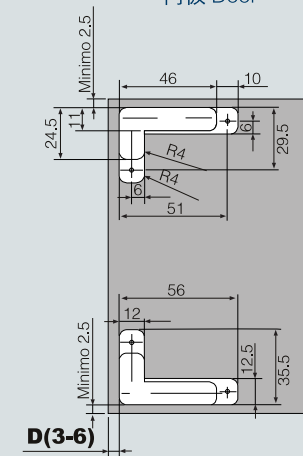

$A = (17 + D) - S$

铰链安装尺寸 Working for the hinge application

$Y = (X - W)$

$W = (X - Y)$

$X = (W + Y)$

